



Overview

KDPT Smart differential pressure transmitter is a well-developed high performance pressure transmitter based on the international leading technology, adopting the World advanced monocrystalline silicon pressure sensor technology and the patented packaging process. This product adopts the patented double overload protection diaphragm design, with the internal circuit surge protection design, and can accurately measure the gauge pressure, flow, vacuum degree, liquid level and density.

Applications and industries

Process control fields for the industries of petroleum, chemical industry, metallurgy, electricity, food, papermaking, medicine, machine manufacturing, scientific experiment and military aviation etc.

Features

- Advanced monocrystalline silicon differential pressure sensor adopted
- Wide pressure range covering $-0.1 \sim 3 \text{MPa}$
- 2-wire mode, $4 \sim 20 \text{mA}$ analog output, HART® protocol digital communication
 - Intelligent LCD gauge with backlight
 - With both remote transmission and local zero and pressure range adjustment
- Complete varieties, high accuracy, good stability
- Isolation ex-proof housing structure, strong resistance to frequency conversion interference
- High static pressure, high overpressure protection
- Patented two pressure ends overpressure protection diaphragm design
- Lightning protection circuit design

Performance parameters

Pressure range	±1kPa; ±6kPa; ±40kPa; ±100kPa; ±250kPa; ±1MPa; ±3MPa
Pressure reference	Differential pressure
Supply voltage	12VDC~32VDC, 24VDC recommended
Output	4~20mA+HART® protocol
ESD (Electronic Static Discharge)	National standard 4 (IEC61000-4-2; GB/T 17626.2), voltage 15KV, contact discharge
EFT (Electrical Fast Transient)	National standard 3 (IEC61000-4-4; GB/T 17626.4), voltage 2KV, pulse length 75ns, frequency 100kHz
Surge	National standard 3 (IEC61000-4-5; GB/T 17626.5), voltage 2KV
Accuracy	±1kPa: ±0.2%FS; ±6kPa: ±0.1%FS; Other standard pressure ranges: ±0.075%FS (25±5°C) ±0.055%FS (25±5°C)
Temp. coefficient	±0.5%FS(±1kPa); ±0.3%FS(±6kPa); ±0.25%FS(Other ranges); @-20°C~70°C
Ambient temperature	-30°C~80°C; with LCD gauge outfit -30°C~70°C
Medium temp.	-40°C~125°C
Protection grade	IP67
Ex-proof grade	Exd IIC T6 Gb
Static pressure range	±1kPa; ±6kPa; ±40kPa Static pressure resistance 16MPa; ±100kPa; -100~250kPa Static pressure resistance 16MPa; -0.1~1MPa; -0.1~3MPa Static pressure resistance 16MPa;
Overpressure limitation	16MPa
Long-term stability	±0.1%FS/year

Structural performance

Diaphragm material	SS316L
Exhaust/Drain valve	SS316
O-ring	Silicone rubber (contact with the measurement medium)
Filling liquid	Silicon oil
Flange and clamp block	SS316L
Housing material	Die-casting aluminum alloy with epoxy resin coating
Electrical connection	M20×1.5 (Female), NPT1/2 (Female)
Process connection	M20×1.5 (Male) with welded pipe, 304 tri-valve set M20×1.5 (Male) with welded pipe
	M20×1.5 with welded pipe, NPT1/4(F), NPT1/2, NPT1/2(F), G1/2 with welded pipe, G1/4 Tri-valve set M20x1.5 with welded pipe (304/316 optional), Tri-valve set NPT1/4F(304/316 optional)
Weight	3.5kg (Optional accessory excluded)

Component diagram

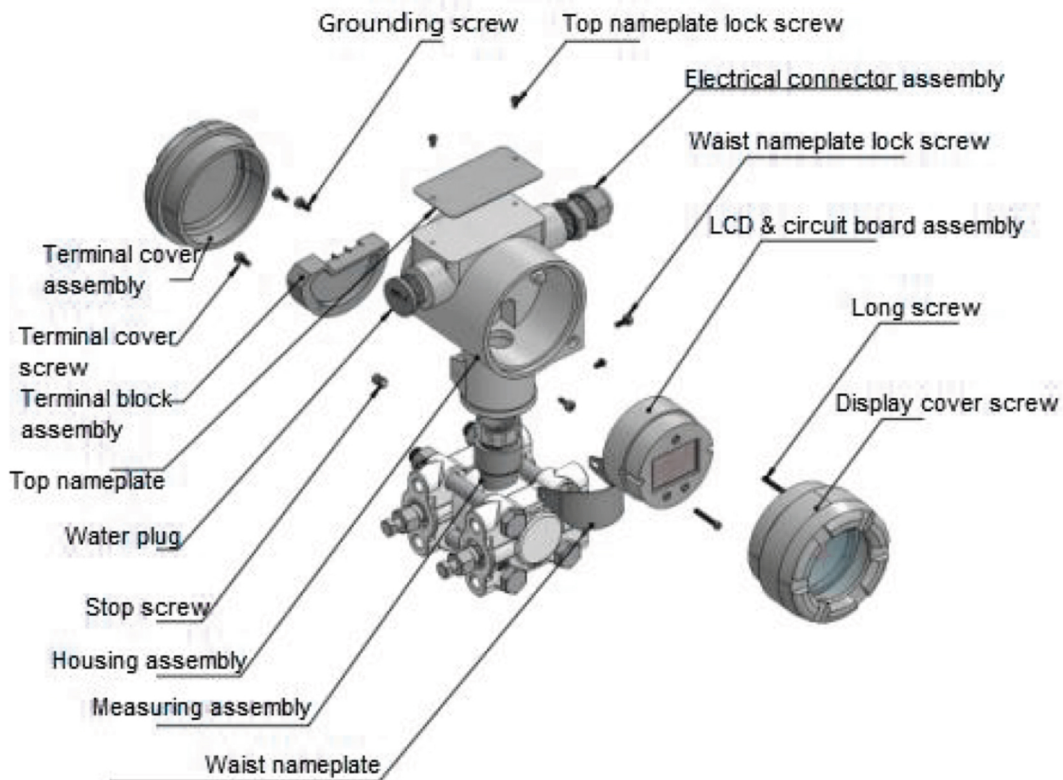

HART communication connection diagram

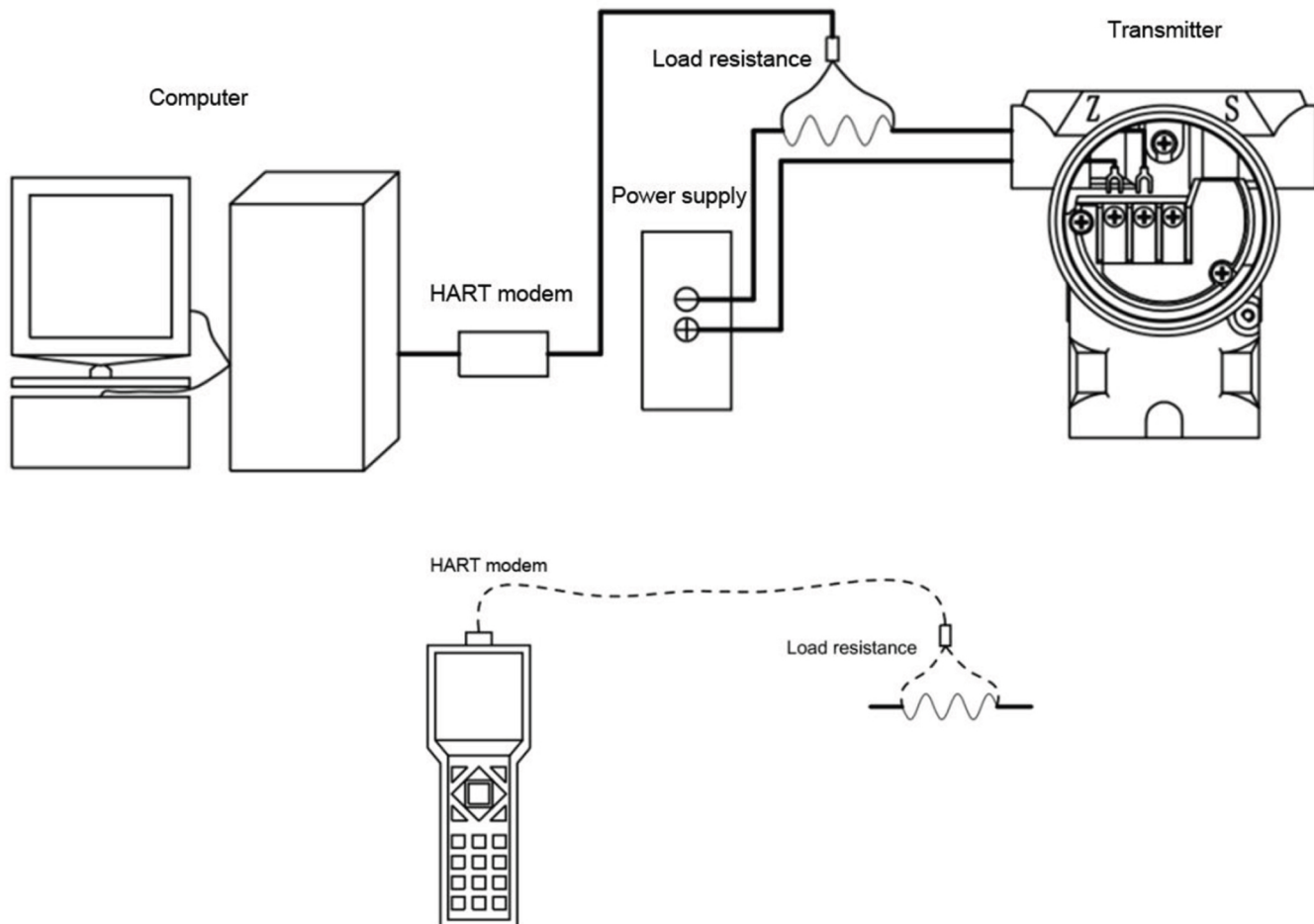

How to order

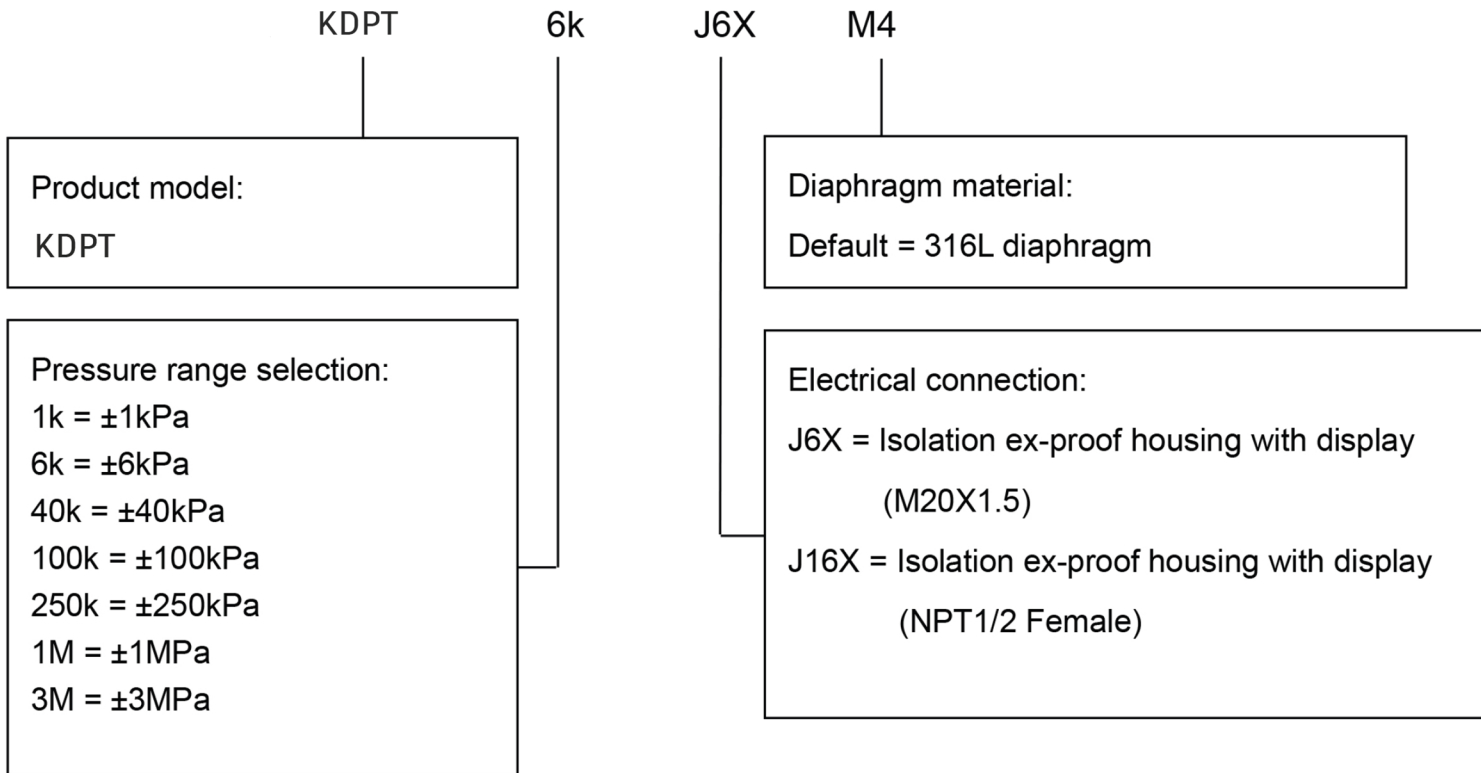

Example: KDPT

Refer to product model: KDPT, pressure range selection: ±6kPa, output: 4~20mA+HART®

protocol, electrical connection: Isolation ex-proof housing with display (M20X1.5 Female), gauge outfit: Kanagawa gauge outfit

How to order for accessories

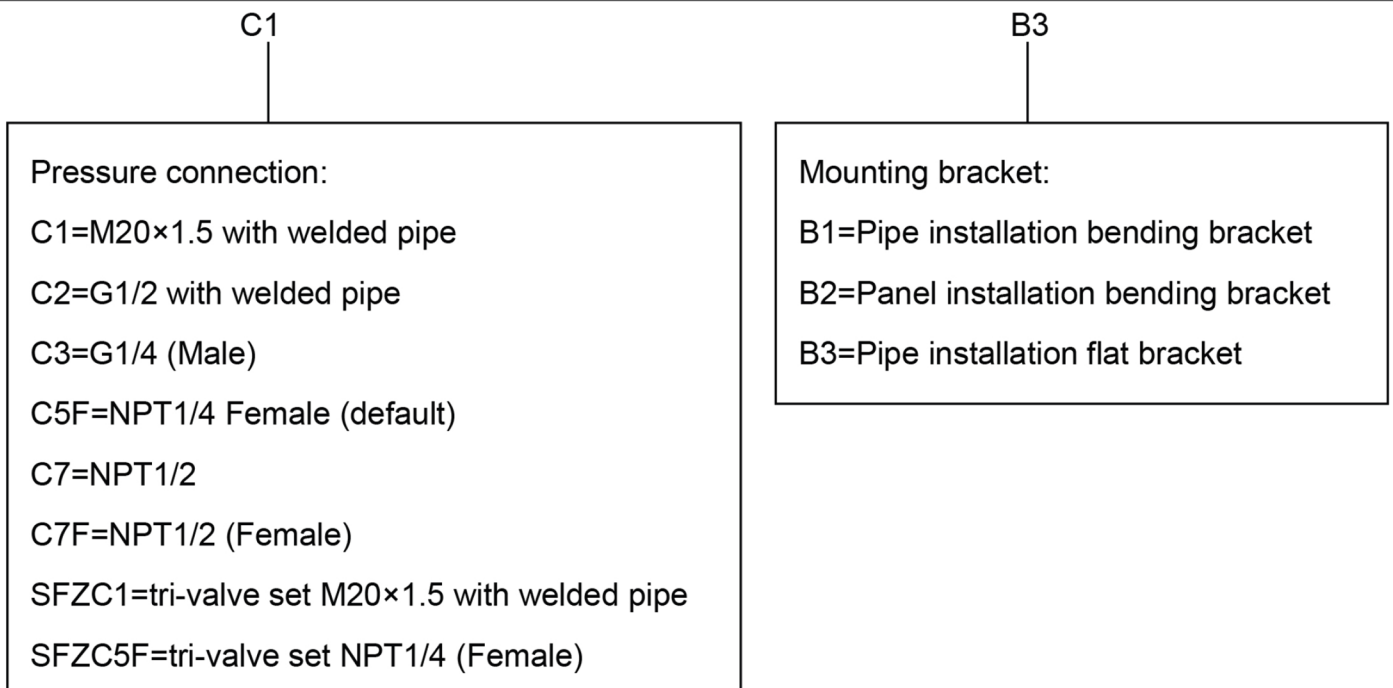

Outline dimension

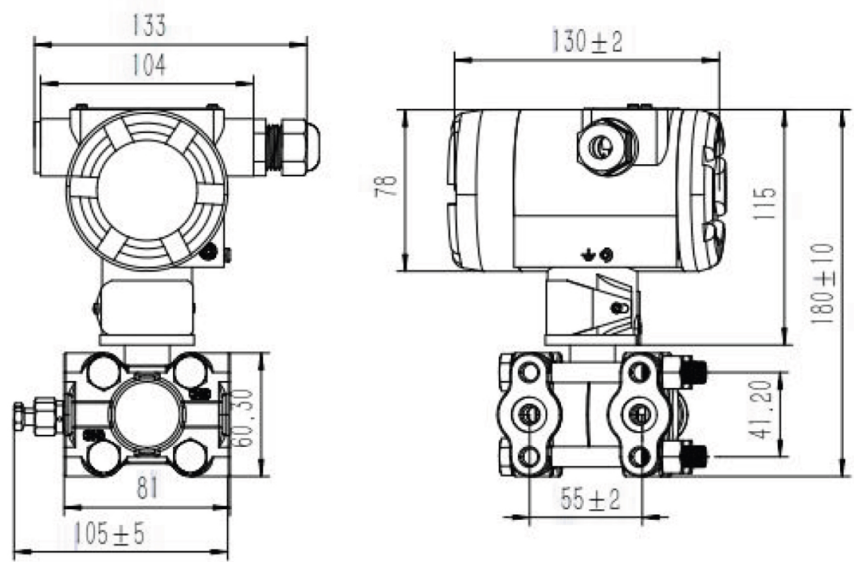
Product model	Dimension drawing	In mm
<p>KDPT (Without accessories)</p>	 <p>Technical drawings of the KDPT instrument showing front, side, and bottom views with dimensions:</p> <ul style="list-style-type: none"> Front view: Overall width 133, mounting bracket width 104, bottom width 81, bottom depth 105 ± 5, and a small offset of 60.30. Side view: Overall height 180 ± 10, top width 130 ± 2, top depth 78, and bottom depth 41.20. Bottom view: Overall width 55 ± 2. 	

Accessory

Mounting bracket In mm

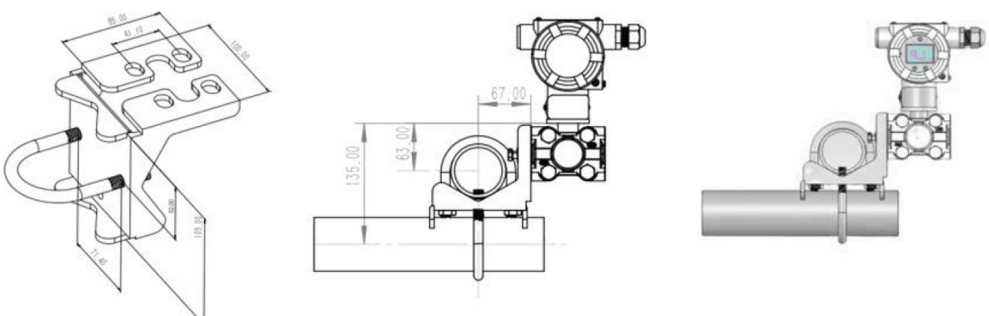
<p>Pipe installation bending bracket: B1</p>	 <p>Technical drawings of the pipe installation bending bracket B1 showing 3D, side, and perspective views. Dimensions include 86.00, 41.00, 104.00, 135.00, 63.00, and 67.00.</p>	
---	--	--

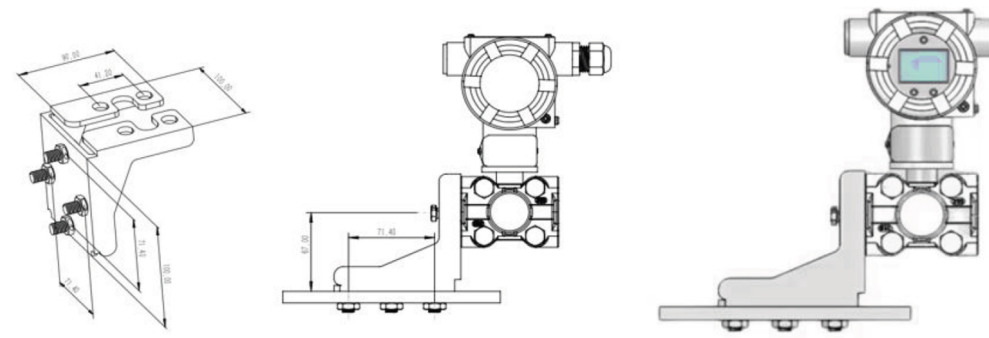
<p>Panel installation bending bracket: B2</p>	 <p>Technical drawings of the panel installation bending bracket B2 showing 3D, side, and perspective views. Dimensions include 86.00, 41.00, 104.00, 67.00, and 71.40.</p>	
--	---	--

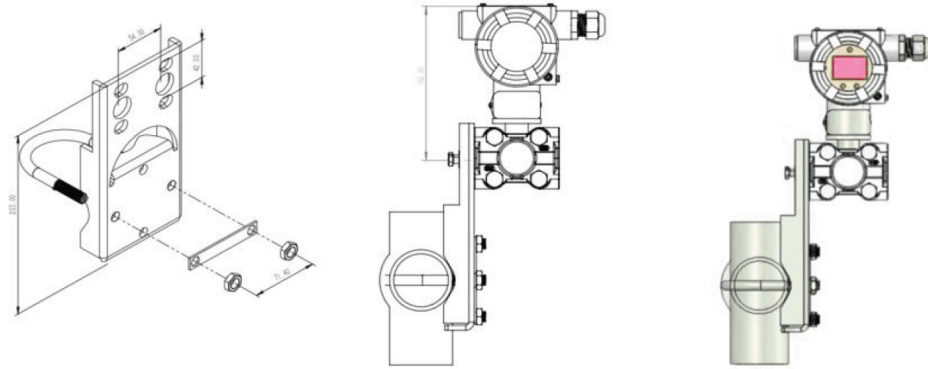
**Pipe installation
flat bracket: B3**

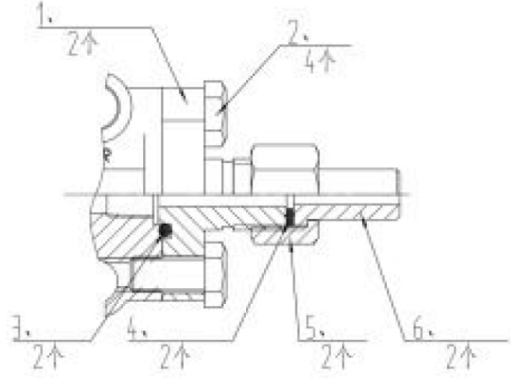
Process connection

Code of accessories	Detail Table			
	Name	Qty	No.	
C1: M20×1.5 with welded pipe	T shape connector	2	1	
	M10×20 bolt	4	2	
	O-ring	2	3	
	PTFE gasket	2	4	
	M20 nut	2	5	
	Φ14×4 welded pipe	2	6	
K7F NPT1/2(F)	No.	Name	Material No.	Qty.
	1	KDPT clamp block	-	2
	2	O-ring	-	2
	3	NPT1/2 pressure connection	100040700010	2
	4	M10×35 bolt	100040700009	4
	-	-	-	-
KFZC1 Tri-valve set-M20 with welded pipe	No.	Name	Material No.	Qty.
	1	KDPT clamp block	-	2
	2	PTFE gasket	-	2
	3	304SS tri-valve set	100040700015	1
	4	M10×35 bolt	-	4
	5	M20 connector	-	2
	6	M20 nut	-	2
	7	PTFE gasket	-	2
8	Φ14×4 welded pipe	-	2	

Note: Please refer to the structural property for the other pressure connections, and the Material No. “-” means provided as the supporting material for free.

Ordering tips

The accessory should be purchased separately.

Kanagawa reserves the right to make any change in this publication without notice. The information provided is believed to be accurate and reliable as of this product sheet.

Notes:

- 1 Do not touch the diaphragm with hard objects, which may cause damage to the diaphragm.
- 2 Please read the Instruction Manual of the product carefully before installation and check the relevant information of the product.
- 3 Strictly follow the wiring method for wiring, otherwise it may cause product damage or other potential faults.
- 4 Misuse of the product may cause danger or personal injury.

Notes:

- 1 Do not touch the diaphragm with hard objects, which may cause damage to the diaphragm.
- 2 Please read the Instruction Manual of the product carefully before installation and check the relevant information of the product.
- 3 Strictly follow the wiring method for wiring, otherwise it may cause product damage or other potential faults.
- 4 Misuse of the product may cause danger or personal injury.